

Galectin-2 suppresses nematode development by binding to the invertebrate-specific galactose β 1-4fucose glyco-epitope

Key words: *Caenorhabditis elegans* / galactose β 1-4fucose / galectin / nematode / parasite

Tomoharu Takeuchi^{1,*}, Mayumi Tamura², Kenji Ishiwata³, Megumi Hamasaki^{4,5},

Shinjiro Hamano^{4,5,6}, Yoichiro Arata², Tomomi Hatanaka^{1,7}

1 Josai University, Faculty of Pharmacy and Pharmaceutical Sciences, 1-1 Keyakidai,

Sakado, Saitama 350-0295, Japan

2 Teikyo University, Faculty of Pharma-Science, 2-11-1 Kaga, Itabashi-ku, Tokyo 173-8605,

Japan

3 The Jikei University School of Medicine, Department of Tropical Medicine, 3-25-8, Nishi-

shinbashi, Minato-ku, Tokyo 105-8461, Japan

4 Nagasaki University, Department of Parasitology, Institute of Tropical Medicine

(NEKKEN), 1-12-4 Sakamoto, Nagasaki, Nagasaki 852-8523, Japan

5 Nagasaki University, The Joint Usage/Research Center on Tropical Disease, Institute of

Tropical Medicine (NEKKEN), 1-12-4 Sakamoto, Nagasaki, Nagasaki 852-8523, Japan

6 Nagasaki University, Leading Program, Graduate School of Biomedical Sciences, 1-12-4

Glycobiology. 2019 Jun 1;29(6):504-512. doi: 10.1093/glycob/cwz022.
<https://academic.oup.com/glycob/article/29/6/504/5381599>

Sakamoto, Nagasaki, Nagasaki 852-8523, Japan

7 Tokai University, School of Medicine, 143 Shimokasuya, Isehara, Kanagawa 259-1193,

Japan

*Corresponding author at: Laboratory of Biochemistry, Faculty of Pharmacy and

Pharmaceutical Sciences, Josai University, 1-1 Keyakidai, Sakado, Saitama 350-0295, Japan

Tel. & Fax: +81-49-271-8123.

E-mail address: t-take@josai.ac.jp (T. Takeuchi)

Running title: Potential antiparasitic ability of galectin-2

Supplementary data: *Supplementary Figure 1:* Multiple sequence alignment of galectin carbohydrate recognition domains; *Supplementary Figure 2:* Dimeric structures of Gal-2 and LEC-6

ABSTRACT

Galactose β 1-4Fucose (GalFuc) is a unique disaccharide found in invertebrates including nematodes. A fungal galectin CGL2 suppresses nematode development by recognizing the galactose β 1-4fucose epitope. The *Caenorhabditis elegans* galectin LEC-6 recognizes it as an endogenous ligand and the Glu⁶⁷ residue of LEC-6 is responsible for this interaction. We found that mammalian galectin-2 (Gal-2) also has a comparable glutamate residue, Glu⁵². In the present study, we investigated the potential nematode-suppressing activity of Gal-2 using *C. elegans* as a model and focusing on Gal-2 binding to the GalFuc epitope. Gal-2 suppressed *C. elegans* development whereas its E52D mutant (Glu⁵² substituted by Asp), galectin-1, and galectin-3 had little effect on *C. elegans* growth. Lectin-staining using fluorescently-labeled Gal-2 revealed that, like CGL2, it specifically binds to the *C. elegans* intestine. Natural *C. elegans* glycoconjugates were specifically bound by immobilized Gal-2. Western blotting with anti-GalFuc antibody showed that the bound glycoconjugates had the GalFuc epitope. Frontal affinity chromatography with pyridylamine-labeled *C. elegans* N-glycans disclosed that Gal-2 (but not its E52D mutant) recognizes the GalFuc epitope. Gal-2 also binds to the GalFuc-bearing glycoconjugates of *Ascaris* and the GalFuc epitope is present in the parasitic nematodes *Nippostrongylus brasiliensis* and *Brugia pahangi*. These results indicate that Gal-2 suppresses *C. elegans* development by binding to its GalFuc epitope. The findings also

Glycobiology. 2019 Jun 1;29(6):504-512. doi: 10.1093/glycob/cwz022.
<https://academic.oup.com/glycob/article/29/6/504/5381599>

imply that Gal-2 may prevent infestations of various parasitic nematodes bearing the GalFuc epitope.

INTRODUCTION

Neglected tropical diseases (NTDs) are a group of infectious diseases and their occurrence is associated with tropical and subtropical poverty. Lymphatic filariasis and soil-transmitted helminthiases are caused by parasitic nematodes and are considered NTDs. The disability-adjusted life-years of these infestations are 2,780,000 and 5,190,000, respectively (Molyneux et al. 2017). Therefore, additional NTD control tools, such as drugs, vaccines, diagnostics, and vector control agents are required (Lustigman et al. 2016; Molyneux et al. 2017). To develop these tools, however, a deeper understanding of host-pathogen interactions is required, especially from a glycobiological perspective.

Glycan structure varies substantially among species. Even simple organisms such as nematodes have complex signature glycans (Cummings 2009; Schiller et al. 2012). The glycans may have important roles in host-parasitic nematode interactions (Hokke and van Diepen 2017; Prasanphanich et al. 2013; Rodrigues et al. 2015). The glyco-epitopes of various potentially pathogenic species may be recognized by host glycan-binding proteins such as Toll-like receptor, C-type lectin receptors, and galectins.

Galectins are a family of sugar-binding proteins in numerous animal species. They are characterized by an evolutionarily conserved carbohydrate recognition domain containing eight conserved amino acid residues necessary for sugar recognition. Galectins

bind to endogenous glycans with a β -galactoside structure such as Gal β 1-4GlcNAc. They participate in development, differentiation, cancer, immunity, and other pathophysiological processes (Thiemann and Baum 2016; Yang et al. 2008). It was recently discovered that galectins recognize exogenous glycans and are involved in host-pathogen interactions (Davicino et al. 2011; Sato et al. 2009; Shi et al. 2018; Vasta et al. 2017). A possible glyco-epitope bound by galectins is Galactose β 1-4Fucose (GalFuc) disaccharide. It occurs in certain invertebrates and could be recognized by mammalian galectins (Prasanphanich et al. 2013).

GalFuc is attached to the innermost GlcNAc residue of *N*-glycans. It is a unique disaccharide epitope found in invertebrates including the octopus *Paroctopus defleini* (Zhang et al. 1997), the squid *Todarodes pacificus* (Takahashi et al. 2003), the marine snails *Megathura crenulata* (Wuhrer et al. 2004) and *Volvarina rubella* (Eckmair et al. 2015), the planarians *Dugesia japonica* (Paschinger et al. 2011) and *Schmidtea mediterranea* (Subramanian et al. 2018), the free-living nematodes *Caenorhabditis elegans* (Hanneman et al. 2006) and *Pristionchus pacificus* (Yan et al. 2015), and the parasitic nematodes *Ascaris suum*, *Oesophagostomum dentatum* (Jimenez-Castells et al. 2017; Yan et al. 2012), and *Haemonchus contortus* (Paschinger and Wilson 2015). The physiological role of the GalFuc epitope is unknown. The galactosyltransferase gene of *C. elegans*, *galt-1*, which is responsible for the synthesis of Gal-Fuc epitope has been identified and is expressed in the

intestine and coelomocytes, although the *C. elegans* strain with a mutation in *galt-1* showed no observable change in phenotype under laboratory conditions (Titz et al. 2009). However, the GalFuc epitope is found in parasitic nematodes and the fungal galectin CGL2 suppresses nematode development by binding to it. Therefore, the GalFuc epitope is proposed as a novel target for anthelmintic agents (Yan et al. 2012).

GalFuc is reported to function as an endogenous recognition unit of LEC-6, a *C. elegans* galectin (Maduzia et al. 2011; Takeuchi et al. 2008; Takeuchi et al. 2009) and is bound by other *C. elegans* galectins as well (Nemoto-Sasaki et al. 2011; Takeuchi et al. 2011). On the other hand, the fungal galectin CGL2 recognizes *C. elegans* GalFuc as an exogenous glyco-epitope and suppresses *C. elegans* development by binding it (Butschi et al. 2010). CGL2 inhibits the larval development of *H. contortus* which also expresses the GalFuc epitope (Heim et al. 2015; Paschinger and Wilson 2015). Certain mammalian galectins can bind to synthetic GalFuc disaccharide derivatives (Takeuchi et al. 2013). Since the GalFuc glyco-epitope is found in parasitic nematodes, mammalian galectins may recognize GalFuc as an exogenous non-self glyco-epitope (as in the case with CGL2) and participate in host defense against parasitic nematode infection.

X-ray crystallography of LEC-6-GalFuc and binding experiments with mutant LEC-6 proteins revealed that the Glu⁶⁷ residue of LEC-6 is important in the specific binding of LEC-6 to the GalFuc epitope in natural *N*-glycans (Makyio et al. 2013) (Supplementary

Figure 1). This Glu residue is also found in CGL2 (Butschi et al. 2010). Therefore, the Glu residue may be important for recognition of GalFuc epitope in natural *N*-glycans. However, it is not conserved across all galectins (Makyio et al. 2013). Through careful comparison of the amino acid sequences of mammalian galectins, we found that this Glu residue is conserved among human and mouse Gal-2 (Supplementary Figure 1) and other mammalian species (data not shown). Gal-2 is expressed mainly in the digestive tract which is a major site of parasitic nematode infection (Nio-Kobayashi 2017). Therefore, we hypothesized that Gal-2 may participate in host defense against parasitic nematode by binding to the GalFuc epitope. The aforementioned Glu residue is also found in mouse Gal-3. However, this galectin has an Asn-Arg-Arg sequence between the Glu residue and Val residue, which is also important for GalFuc recognition. For this reason, Gal-3 may not effectively recognize GalFuc in natural *N*-glycans.

In the present study, we investigated the potential nematode suppression ability of mammalian galectin-2 (Gal-2) using *C. elegans* and focused on Gal-2 binding to the GalFuc glyco-epitope.

RESULTS

Galectin-2 suppresses C. elegans development

C. elegans glycoconjugates contain structural motifs found in other nematodes. Therefore, *C. elegans* could serve as a model for other nematodes especially in protein-carbohydrate interaction investigations (Jankowska et al. 2018). To clarify the nematode-suppressing potential of Gal-2, we prepared recombinant galectin proteins and examined their effects on the development of the free-living nematode *C. elegans* as a model for parasitic nematodes. A recombinant protein for CGL2 which has been reported to suppress *C. elegans* development (Butschi et al. 2010) was also prepared and used as a positive control. The L1 larval stage of *C. elegans* was grown in liquid culture in the presence of various galectins. The proportions of developmentally arrested worms are shown in Figure 1. Only Gal-2 and CGL2 suppressed *C. elegans* development. In contrast, the mGal-2E52D (Glu⁵² substituted by Asp) mutant, which was presumed to have little affinity for GalFuc, had minimal effect on *C. elegans* development compared with wild type mGal-2.

Gal-2 binds to C. elegans glycoconjugates containing GalFuc epitope in vitro and in vivo

Since Gal-2 suppressed *C. elegans* development, we investigated whether it binds to natural glycoconjugates with GalFuc epitopes. To localize Gal-2 binding partners *in vivo*, we fed worms with fluorescently labeled Gal-2 and then rinsed them with lactose or maltose. The latter served as an osmotic control (Figure 2). The fluorescent signal was observed in *C.*

elegans intestine with the maltose wash but not with lactose. Gal-2 binds to intestinal glyco-epitope in a β -galactoside-dependent manner as is does with CGL2.

To identify the Gal-2 binding partners *in vitro*, we applied a *C. elegans* extract to an immobilized Gal-2 column. After extensive washing, we eluted the bound materials with lactose (Figure 3A). SDS-PAGE and Coomassie brilliant blue (CBB) staining revealed multiple proteins in the lactose-eluted fractions such as Fr. 10. Western blotting with anti-Gal β 1-4Fuc antibody (Takeuchi et al. 2015) showed *C. elegans* glycoconjugates with the GalFuc epitope are present in the lactose-eluted fractions (Figure 3B). To identify the proteins bound by Gal-2, the indicated protein bands were excised from the gel and digested with trypsin. The peptide products were subjected to liquid chromatography/tandem mass spectrometry (LC-MS/MS) to assign the proteins (Figure 3C). The Gal-2-binding proteins were VIT-2, F28B4.3, T25C12.3, VIT-6, menocentin, etc.

Gal-2 recognizes GalFuc epitope in natural C. elegans N-glycans

It was presumed that Gal-2 has an affinity for the GalFuc epitope. Therefore, we explored the ability of Gal-2 to bind GalFuc using frontal affinity chromatography. We used commercially available pyridylamine (PA)-labeled sugars containing Gal β 1-4GlcNAc epitope and PA-labeled natural *C. elegans* N-glycans containing GalFuc epitope which could be bound by the *C. elegans* galectin LEC-6 (Takeuchi et al. 2008) (Figure 4). WT Gal-2 had

affinities for LnNT and NA2-PA which contain one or two Gal β 1-4GlcNAc epitopes. It also had affinities for D2, D4, E3, and E4-PA, each of which contains one GalFuc epitope. Gal-2 had little affinity for degalactosylated E4-PA (DeE4-PA). However, the E52D mutant of mouse Gal-2 showed weaker affinities for these sugars than the wild type. These results suggest that Gal-2 recognizes the GalFuc epitope in the natural *N*-glycans of *C. elegans* in a galactose-dependent manner. Moreover, the Glu⁵² of Gal-2 is important for the recognition of these sugars as in the case of the *C. elegans* galectin LEC-6.

Gal-2 binds to Ascaris glycoconjugates with the GalFuc epitope which is also found in other parasitic nematodes

The aforementioned results suggest that Gal-2 affects the free-living nematode *C. elegans* by binding to the GalFuc epitope. Therefore, we investigated whether Gal-2 binds to the GalFuc-bearing glycoconjugates of the parasitic nematode *Ascaris suum*. An *A. suum* extract was applied to an immobilized Gal-2 column. After extensive washing, the bound materials were eluted with lactose and the collected fractions were subjected to western blotting with the anti-Gal β 1-4Fuc antibody (Figure 5A). GalFuc-bearing glycoconjugates of *A. suum* were found in the lactose-eluted fractions (Frs. 10, 11). Therefore, Gal-2 can bind to GalFuc epitope from parasitic nematodes as well as the free-living nematode *C. elegans*. Gal-2 may also affect parasitic nematodes by binding to the GalFuc epitope.

The presence of GalFuc epitope in parasitic species has only been reported in *Ascaris suum*, *Oesophagostomum dentatum*, and *Haemonchus contortus* (Jimenez-Castells et al. 2017; Paschinger and Wilson 2015; Takeuchi et al. 2015; Yan et al. 2012). We sought the presence of the GalFuc epitope in other well-studied parasitic nematodes *Nippostrongylus brasiliensis* (Nb) and *Brugia pahangi* (Bp) and the trematode *Schistosoma mansoni* (Sm) using anti-Gal β 1-4Fuc antibody. We prepared extracts of various helminth developmental stages, and human HeLa cells, which is a negative control for the antibody, and subjected them to western blotting (Figure 5B). Only the proteins in the Nb and Bp extracts gave positive signals. The band patterns varied with developmental stage. Therefore, these parasitic nematodes may have the GalFuc epitope and their development could be affected by Gal-2.

DISCUSSION

In the present study, we investigated the effects of Gal-2 on nematodes and found that Gal-2 (but not its E52D mutant) suppresses the development of *C. elegans*, recognizes natural *C. elegans* N-glycans and glycoconjugates containing GalFuc epitope, and binds to *Ascaris* glycoconjugates containing GalFuc epitope which is also found in other parasitic nematodes. It has already been reported that the mammalian galectin Gal-11 suppresses the

gastrointestinal parasitic nematode *H. contortus* (Preston et al. 2015). To the best of our knowledge, the present study is the first to report that the mammalian galectin Gal-2 suppresses nematode development by interacting with the invertebrate-specific GalFuc glyco-epitope.

Gal-2 but not its E52D mutant suppressed *C. elegans* development (Figure 1). Therefore, GalFuc epitope recognition is important in Gal-2 suppression of *C. elegans* development. Its binding partners were glycoconjugates with the GalFuc epitope. The E52D mutation reduced the affinity of Gal-2 for natural *C. elegans* N-glycans containing the GalFuc epitope.

The E52D mutation reduced the affinity of Gal-2 by > 90% for E3-PA and E4-PA containing the GalFuc epitope (Figure 4). However, this mutation also reduced Gal-2 affinity by ~80% for LnNT-PA and NA2-PA which contain Gal β 1-4GlcNAc disaccharide unit(s). The E52D mutation of Gal-2 affected its affinity for both GalFuc and Gal β 1-4GlcNAc. Since the Glu⁵² of Gal-2 is localized in its sugar-binding site, the E52D mutation of Gal-2 may have caused a slight conformational change there. The Glu⁵² of Gal-2 is adjacent to Cys⁵⁷ which is responsible for its oxidative inactivation (Sakakura et al. 2018; Tamura et al. 2016).

Therefore, the E52D mutant could be more susceptible to oxidative inactivation than its wild type counterpart. A certain part of the protein may have been inactivated during the experiment. Gal-2 non-classically interacts with lactose (Gal β 1-4Glc) and the Glu⁵² of Gal-2

participates in this interaction (Si et al. 2016). For this reason, Glu⁵² might be important in the recognition of both Gal β 1-4GlcNAc and GalFuc. However, the reduction in the affinity for E3-PA and E4-PA caused by the E52D mutation was greater than that for LnNT-PA and NA2-PA. Consequently, the Glu⁵² of Gal-2 is presumed to be important in its recognition of the GalFuc epitope.

The Gal-2 binding partners were highly similar to those of the *C. elegans* endogenous galectin LEC-6 and possibly to those of the fungal galectin CGL2 as well. The binding partners of Gal-2 are localized in the intestine (Figure 2) as are the glycoconjugate ligands for LEC-6 and CGL2 (Butschi et al. 2010; Maduzia et al. 2011). The gene *galt-1*, which encodes the galactosyltransferase responsible for GalFuc epitope biosynthesis, is also expressed in the intestine (Titz et al. 2009). The Gal-2-binding proteins VIT-2, F28B4.3, T25C12.3, VIT-6, and menocentin (Figure 3) are binding partners for the *C. elegans* galectin LEC-6 (Hirabayashi et al. 2002; Kaji et al. 2007; Maduzia et al. 2011; Takeuchi et al. 2011). Gal-2 specifically binds to the GalFuc epitope of *C. elegans* N-glycans (Figure 4), as well as LEC-6, and CGL2 (Butschi et al. 2010; Takeuchi et al. 2008).

However, only Gal-2 and CGL2 effectively suppressed *C. elegans* development (Figure 1) possibly because of the differences in the quaternary structures of LEC-6, Gal-2, and CGL2. CGL2 forms a tetramer (Walser et al. 2004) whereas LEC-6 and Gal-2 form dimers (Lobsanov et al. 1993; Makyio et al. 2013; Si et al. 2016). Nevertheless, their overall

dimer structures and subunit orientations differ (Supplementary Figure 2). Therefore, LEC-6 and Gal-2 may bind to similar ligands but crosslink them differently. For this reason, they have different effects on *C. elegans*.

Gal-2 binds to glycoconjugates containing the GalFuc epitope in the parasitic nematode *A. suum* as well as that of the free-living nematode *C. elegans*. Since CGL2 suppresses *C. elegans* and *H. contortus* (Butschi et al. 2010; Heim et al. 2015) which both have the GalFuc epitope, Gal-2 may also suppress the development of parasitic nematodes such as *A. suum* with the GalFuc epitope. *N. brasiliensis*, a model nematode for soil-borne helminthiasis, and *B. pahangi*, a model nematode for lymphatic filariasis, both have the GalFuc epitope (Figure 5). Therefore, it would be interesting to explore the functions of Gal-2 on these parasitic nematodes and the diseases they cause. In contrast, the glycoconjugates of the parasitic trematode *S. mansoni* did not react with anti-GalFuc antibody. Glycomic analysis of this trematode indicated that it expresses Gal β 1-4GlcNAc (LacNAc) and GalNAc β 1-4GlcNAc (LacDiNAc) but not GalFuc (Smit et al. 2015). However, *S. mansoni* glycoconjugates are recognizable by the mammalian galectin Gal-3 (van den Berg et al. 2004). Lectin blotting analysis with Gal-2 disclosed that Gal-2 binds to *S. mansoni* glycoconjugates (data not shown). Consequently, Gal-2 could influence the infectivity of this parasitic trematode.

Suppression of *C. elegans* by Gal-2 was $\sim 5\times$ weaker than that of CGL2 (data not

shown). The concentration of Gal-2 used in the present experiment was much higher than its physiological concentration in human serum ($\leq \sim 1 \mu\text{g/mL}$) (Barrow et al. 2011; Nio-Kobayashi 2017). However, galectins are considered to be abundantly expressed in tissues, e.g. the concentration of Gal-1 protein is $\sim 40 \text{ mg/kg}$ (Ahmed et al. 1996) and Gal-2 is mainly expressed in the digestive tract rather than serum (Nio-Kobayashi 2017). In addition, local galectin concentrations may be high at infection sites because the galectins are locally secreted by cells as they are being destroyed by infection (Sato et al. 2009). Under physiological conditions, Gal-2 may collaborate with other proteins such as mucin (Tamura et al. 2017) which is important in host defense against parasitic nematodes (Hasnain et al. 2013). This cooperation could enhance Gal-2 activity against *C. elegans*. In view of the preceding facts and presumptions and the fact that Gal-2 but not Gal-1 or Gal-3 suppressed *C. elegans* (Figure 1), Gal-2 may specifically suppress nematodes. The precise effects of Gal-2 on parasitic nematodes is unknown. On the other hand, the results of this study clearly indicate that Gal-2 may participate in host defense against infestations by parasitic nematodes bearing the GalFuc epitope. To test this hypothesis, the effects of administering recombinant Gal-2 protein or Gal-2 knockout on animals infested with parasitic nematodes should be investigated.

In conclusion, the results of the present study suggest that Gal-2 suppresses *C. elegans* development by interacting with the invertebrate-specific GalFuc glyco-epitope,

although this is a model study using the free-living nematode *C. elegans* as a model for parasitic nematodes. However, CGL2, which recognizes GalFuc as in the case of Gal-2, suppresses both *C. elegans* and the parasitic nematode *H. contortus*. Therefore, Gal-2 may also inhibit parasitic nematodes such as *N. brasiliensis* and *B. pahangi* which both have the GalFuc epitope. This theory merits further investigation and we are planning to test this hypothesis. Since the GalFuc epitope is widely distributed in Phylum Nematoda (Takeuchi et al. 2016), targeting it with Gal-2 and/or Gal-2-Toxin conjugate as described by Tateno et al. (2017) might be suitable in the diagnosis and treatment of NTDs such as lymphatic filariasis and soil-borne helminthiasis.

MATERIALS AND METHODS

Materials

The Bristol N2 strain of *C. elegans* used in the present study was provided by the Caenorhabditis Genetics Center of the National Center for Research Resources of the National Institutes of Health. For frontal affinity chromatography, the following pyridylaminated sugars (PA-sugars) were purchased or prepared: LNnT-PA (PA041; Gal β 1-4GlcNAc β 1-3Gal β 1-4Glc-PA), NA2-PA (PA001; Gal β 1-4GlcNAc β 1-2Man α 1-3 (Gal β 1-4GlcNAc β 1-2Man α 1-6) Man β 1-4GlcNAc β 1-4GlcAc-PA), and rhamnose-PA were acquired

from TaKaRa Bio (Kusatsu, Shiga, Japan). D2-PA, D4-PA, E3-PA, and E4-PA (PA derivatives of natural *N*-glycans containing the Gal β 1-4Fuc unit isolated from *C. elegans* (Figure 4A)) and degalactosylated E4-PA were prepared as reported previously (Takeuchi et al. 2008).

Preparation of recombinant proteins

Human galectin-2 (hGal-2), mouse galectin-2 (mGal-2), mGal-1C2S, mGal3, and LEC-6 recombinant proteins were expressed in *Escherichia coli* and affinity-purified with an asialofetuin- or Gal β 1-4Fuc-immobilized sepharose column (Takeuchi et al. 2011) basically as described previously (Takeuchi et al. 2008; Takeuchi et al. 2009; Takeuchi et al. 2013).

The E52D mutant of mGal-2 was generated by PCR using the following primers: 5'-ATCCACCATTGTCTGTAAC-3' and 5'-TCATCGAAGCGAGGGTTAAAATG-3'. The substitution site is underlined. For the CGL2-expressing plasmid, the artificial gene encoding CGL2 protein with optimized codon usage was synthesized by Fasmac (Kanagawa, Japan) and subcloned into the *Nde*I and *Bam*I sites of the pET21a vector. The resultant pET-mGal-2E52D and pET-CGL2 plasmids were used for protein expression as described above.

C. elegans developmental assay

Mixed-stage *C. elegans* was treated with bleach (aqueous sodium hypochlorite) to isolate the eggs which were then incubated in M9 buffer for 1 d. The hatched L1 worms were used for

the developmental assay. Approximately 20 L1 worms/10 μ L of M9 buffer, 10 μ L OP50-WT ($OD_{600} = 20$), 20 μ L of 5 mg/mL recombinant galectin protein in PBS (8.1 mM Na_2HPO_4 , 1.47 mM KH_2PO_4 , 137 mM NaCl, and 2.68 mM KCl; pH 7.4), and 60 μ L M9 buffer were added to each well of a 96-well flat plate. After 63-69 h incubation at 20°C, the % of animals developing to L4 was scored. Data are expressed as means \pm SD. The recombinant protein used was presterilized by filtration 0.22 μ m syringe filter.

C. elegans lectin staining

Alexa488-labeled mGal-2 was prepared with an Alexa Fluor™ 488 protein labeling kit (Thermo Fisher Scientific, Waltham, MA, USA) essentially according to the manufacturer's instructions. Mixed-stage *C. elegans* were harvested from the nematode growth medium (NGM) plate with M9 buffer. For lectin staining, 50 μ L *C. elegans* in M9 buffer, 40 μ L PBS, and 10 μ L of 1.27 mg/mL Alexa488-labeled mGal-2 were mixed and incubated for 2 h at 20°C. To confirm β -galactoside-dependent staining, stained worms were washed 2 times with PBS containing either 0.1 M lactose or 0.1 M maltose (control) and fluorescence images were taken with a FLoid™ Cell Imaging Station (Life Technologies, Carlsbad, CA, USA) using a 20 \times objective.

Isolation of C. elegans and Ascaris glycoproteins interacting with mouse galectin-2

Mixed-stage *C. elegans* strain N2 were grown under standard laboratory conditions and harvested in M9 buffer. *C. elegans* \leq 200 mg was dissolved by sonication in PBS containing 1 mM EDTA. After centrifugation, the *C. elegans* extract was applied to an immobilized mGal-2 column (bed volume 1 mL; 15.8 mg protein/mL gel) prepared as described above. The column was washed extensively with PBS containing 1 mM EDTA and the adsorbed materials were eluted with PBS containing 0.1 M lactose and 1 mM EDTA. The operating temperature was 4°C. The fraction volume was ~1 mL throughout the experiment. Each fraction was subjected to trichloroacetic acid (TCA) precipitation as described previously (Takeuchi et al. 2011). The precipitated materials were resuspended in a sodium dodecyl sulfate (SDS)-sample buffer (50 mM Tris-HCl, pH 6.8; 1% SDS; 8% glycerol; 0.01% bromophenol blue; and 2% of 2-mercaptoethanol) then subjected to SDS-PAGE and western blotting.

To isolate mGal-2-binding glycoproteins from *Ascaris*, lyophilized protein powder derived from *Ascaris suum* crude extract was obtained from Cosmo Bio (Tokyo, Japan) and dissolved in 1.6 mL ultrapure water according to the manufacturer's recommendation. The *Ascaris* extract was applied to an immobilized mGal-2 column and mGal-2-binding glycoproteins were isolated as described above.

To identify the mGal-2-binding glycoproteins, the portion of the gel indicated in Figure 3C was excised and the proteins therein were identified via a contract analytical

service of Tokushima University. In brief, the proteins in the excised gel were digested with trypsin and the resultant peptide mixture was subjected to nanoLC-MS/MS. The LC-MS consisted of a nanoLC system (UltiMate 3000 RSLCnano; Thermo Fisher Scientific, Waltham, MA, USA) and an ESI-IT MS system (Orbitrap Elite; Thermo Fisher Scientific, Waltham, MA, USA). The MS/MS spectra were searched against the *C. elegans* protein database downloaded from the National Center for Biotechnology Information (NCBI; Bethesda, MD, USA) website (<http://www.ncbi.nlm.nih.gov/>).

Frontal affinity chromatography

Immobilization of recombinant WT mGal-2 or its E52D mutant on HiTrap NHS-activated sepharose (GE Healthcare, St. Giles, UK) and frontal affinity chromatography were performed basically as described previously (Takeuchi et al. 2008). In brief, each PA-sugar at 5 nM concentration was applied to an immobilized galectin column at a flow rate of 0.25 mL/min and at 20 °C. The elution profile was monitored by a fluorescence detector. K_d for the interaction between galectin and PA-sugar was determined according to the following basic frontal affinity chromatography equation:

$$K_d = B_v / (V - V_0) - [A]_0 \quad (1)$$

where B_t is the effective ligand content, V is the elution front volume, V_0 is V for rhamnose-PA not bound by galectins, and $[A]_0$ is the initial PA-sugar concentration. If $[A]_0$ is negligibly smaller than K_d , then the equation can be simplified as $K_d = B_t/(V_f - V_0)$. In the present study, B_t for the immobilized mGal-2 E52D column was calculated from the data obtained from concentration-dependent analysis using various concentrations of Gal β 1-4Fuc and PA-Gal β 1-4Fuc (Nishiyama et al. 2010) (data not shown). The B_t for the mGal-2 WT column was calculated from the K_d value reported for the interaction between mGal-2 and PA-Gal β 1-4Fuc (Takeuchi et al. 2013) (data not shown). K_a were calculated on the basis of the following equation:

$$K_a = 1/K_d \quad (2)$$

Preparation of HeLa cell and parasite extracts

The human HeLa cell line was obtained from the RIKEN Cell Bank (Tsukuba, Japan) and maintained in Dulbecco's modified Eagle's medium (DMEM; Wako Pure Chemical Industries Ltd., Osaka, Japan) containing 10% heat-inactivated fetal bovine serum (FBS; Thermo Fisher Scientific, Waltham, MA, USA) and $1 \times$ penicillin/streptomycin (Wako Pure Chemical Industries Ltd., Osaka, Japan) under a humidified 5% CO₂ atmosphere at 37°C. The HeLa extracts were prepared by lysing the cells by sonication and boiling in SDS-PAGE sample

buffer.

To prepare *Nippostrongylus brasiliensis* (Nb), mice were infected with Nb by subcutaneous injection with third-stage larvae. After 2 d, L4 larvae were collected from the lungs. After 4 d, L5 larvae were collected from the small intestines. After 6 d, adult Nb were collected from the small intestines according to the description by Haley (1962). The life cycle of *Brugia pahangi* (Bp) was maintained by serial passage through mosquitoes (*Aedes aegypti*) and jirds (*Meriones unguiculatus*) in the animal facilities of Nagasaki University, Japan. To prepare Bp, mosquitoes were allowed to ingest the blood of jirds positive for circulating microfilariae. Approximately 2 wk after this feeding, L3 larvae were collected from infected mosquitoes. A Puerto Rican strain of *Schistosoma mansoni* (Sm) was maintained in the animal facilities of Nagasaki University by passage through *Biomphalaria glabrata* snails and ICR mice. To prepare the Sm, mice were percutaneously infected with cercariae. Approximately 9 wk after infection, adult worms were collected from the portal veins near the livers and the eggs were collected from the livers. The parasites and eggs were lysed by sonication and boiling in SDS-PAGE sample buffer. All animal experiments were approved by the Institutional Animal Care and Use Committee of the Jikei University (The Jikei IACUC; No. 2016-100) or the Institutional Animal Research Committee of Nagasaki University (No. 1612081349) and performed according to Japanese law for the Humane Treatment and Management of Animals (No. 105; dated October 19, 1973 and amended June

2, 2006).

Western blotting using anti-Galactose β 1-4Fucose polyclonal antibody

Protein samples dissolved in SDS-sample buffer were subjected to SDS-PAGE. The separated proteins were transferred onto nitrocellulose membranes with an iBlot2 Gel Transfer Device (Life Technologies, Carlsbad, CA, USA). Immunoblotting was performed on an iBind Western Device (Life Technologies, Carlsbad, CA, USA) according to the manufacturer's instruction with anti-Galactose β 1-4Fucose rabbit polyclonal antibody (Takeuchi et al. 2015). The blots were visualized with Luminata Crescendo (Merck Millipore, Burlington, MA, USA) and the signals were detected with ChemiDoc XRS+ (Bio-Rad Laboratories, Hercules, CA, USA).

CONFLICT OF INTEREST

The authors have no financial conflicts of interest to disclose concerning this manuscript.

ACKNOWLEDGEMENTS

This study was supported in part by JSPS KAKENHI, a Grant-in-Aid for Young Scientists (B; No. 15K18506), and by research grants from Josai University. We would like to thank Editage (www.editage.jp) for English language editing.

ABBREVIATIONS

Bp, *Brugia pahangi*

CBB, Coomassie brilliant blue

DMEM, Dulbecco's modified Eagle's medium

EDTA, ethylenediaminetetraacetic acid

FBS, fetal bovine serum

Gal-1, galectin-1

Gal-2, galectin-2

Gal-3, galectin-3

GalFuc, Galactose β 1-4Fucose

ICR, Institute of Cancer Research

LC-MS/MS, liquid chromatography-tandem mass spectrometry

Nb, *Nippostrongylus brasiliensis*

NGM, nematode growth medium

NTD, neglected tropical diseases

PA, pyridylamine

PBS, phosphate-buffered saline

SDS-PAGE, sodium dodecyl sulfate polyacrylamide gel electrophoresis

Sm, *Schistosoma mansoni*

TCA, trichloroacetic acid

WT, wild type

REFERENCES

- Ahmed H, Fink NE, Pohl J, Vasta GR. 1996. Galectin-1 from bovine spleen: biochemical characterization, carbohydrate specificity and tissue-specific isoform profiles. *J Biochem.* 120:1007–1019.
- Barrow H, Guo X, Wandall HH, Pedersen JW, Fu B, Zhao Q, Chen C, Rhodes JM, Yu LG. 2011. Serum galectin-2, -4, and -8 are greatly increased in colon and breast cancer patients and promote cancer cell adhesion to blood vascular endothelium. *Clin Cancer Res.* 17:7035–7046.
- Butschi A, Titz A, Walti MA, Olieric V, Paschinger K, Nobauer K, Guo X, Seeberger PH, Wilson IB, Aebi M, *et al.* 2010. *Caenorhabditis elegans* N-glycan core beta-galactoside confers sensitivity towards nematotoxic fungal galectin CGL2. *PLoS Pathog.* 6:e1000717.
- Cummings RD. 2009. The repertoire of glycan determinants in the human glycome. *Mol Biosyst.* 5:1087–1104.
- Davicino RC, Elicabe RJ, Di Genaro MS, Rabinovich GA. 2011. Coupling pathogen recognition to innate immunity through glycan-dependent mechanisms. *Int*

Glycobiology. 2019 Jun 1;29(6):504-512. doi: 10.1093/glycob/cwz022.
<https://academic.oup.com/glycob/article/29/6/504/5381599>

Immunopharmacol. 11:1457–1463.

Eckmair B, Jin C, Abed-Navandi D, Paschinger K. 2015. Multi-step fractionation and mass spectrometry reveals zwitterionic and anionic modifications of the *N*- and *O*-glycans of a marine snail. *Mol Cell Proteomics.* 15:573–597.

Haley AJ. 1962. Biology of the rat nematode, *Nippostrongylus brasiliensis* (Travassos, 1914).

II. Preparastic stages and development in the laboratory rat. *J Parasitol.* 48:13–23.

Hanneman AJ, Rosa JC, Ashline D, Reinhold VN. 2006. Isomer and glycomer complexities of core GlcNAcs in *Caenorhabditis elegans*. *Glycobiology.* 16:874–890.

Hasnain SZ, Gallagher AL, Grecis RK, Thornton DJ. 2013. A new role for mucins in immunity: insights from gastrointestinal nematode infection. *Int J Biochem Cell Biol.* 45:364–374.

Heim C, Hertzberg H, Butschi A, Bleuler-Martinez S, Aebi M, Deplazes P, Kunzler M, Stefanic S. 2015. Inhibition of *Haemonchus contortus* larval development by fungal lectins. *Parasit Vectors.* 8:425.

Hirabayashi J, Hayama K, Kaji H, Isobe T, Kasai K. 2002. Affinity capturing and gene assignment of soluble glycoproteins produced by the nematode *Caenorhabditis elegans*. *J Biochem.* 132:103–114.

Hokke CH, van Diepen A. 2017. Helminth glycomics - glycan repertoires and host-parasite interactions. *Mol Biochem Parasitol.* 215:47–57.

Glycobiology. 2019 Jun 1;29(6):504-512. doi: 10.1093/glycob/cwz022.
<https://academic.oup.com/glycob/article/29/6/504/5381599>

- Jankowska E, Parsons LM, Song X, Smith DF, Cummings RD, Cipollo JF. 2018. A comprehensive *Caenorhabditis elegans* N-glycan shotgun array. *Glycobiology*. 28:223–232.
- Jimenez-Castells C, Vanbeselaere J, Kohlhuber S, Ruttkowski B, Joachim A, Paschinger K. 2017. Gender and developmental specific N-glycomes of the porcine parasite *Oesophagostomum dentatum*. *Biochim Biophys Acta*, 1861:418-430.
- Kaji H, Kamiie J, Kawakami H, Kido K, Yamauchi Y, Shinkawa T, Taoka M, Takahashi N, Isobe T. 2007. Proteomics reveals N-linked glycoprotein diversity in *Caenorhabditis elegans* and suggests an atypical translocation mechanism for integral membrane proteins. *Mol Cell Proteomics*. 6:2100–2109.
- Lobsanov YD, Gitt MA, Leffler H, Barondes SH, Rini JM. 1993. X-ray crystal structure of the human dimeric S-Lac lectin, L-14-II, in complex with lactose at 2.9-Å resolution. *J Biol Chem*. 268:27034–27038.
- Lustigman S, Hotez PJ, Pecoul B, Rijal S, Boehme C, Aksoy S, Malecela M, Tapia-Conyer R, Reeder JC. 2016. Eliminating the neglected tropical diseases: translational science and new technologies. *PLoS Negl Trop Dis*. 10:e0003895.
- Maduzia LL, Yu E, Zhang Y. 2011. *Caenorhabditis elegans* galectins LEC-6 and LEC-10 interact with similar glycoconjugates in the intestine. *J Biol Chem*. 286:4371–4381.
- Makyio H, Takeuchi T, Tamura M, Nishiyama K, Takahashi H, Natsugari H, Arata Y, Kasai KI, Yamada Y, Wakatsuki S, *et al.* 2013. Structural basis of preferential binding of fucose-

Glycobiology. 2019 Jun 1;29(6):504-512. doi: 10.1093/glycob/cwz022.
<https://academic.oup.com/glycob/article/29/6/504/5381599>

containing saccharide by the *Caenorhabditis elegans* galectin LEC-6. *Glycobiology*. 23:797–805.

Molyneux DH, Savioli L, Engels D. 2017. Neglected tropical diseases: progress towards addressing the chronic pandemic. *The Lancet* 389:312–325.

Nemoto-Sasaki Y, Takai S, Takeuchi T, Arata Y, Nishiyama K, Yamada A, Takahashi H, Natsugari H, Kasai K. 2011. The DC2.3 Gene in *Caenorhabditis elegans* encodes a galectin that recognizes the galactose β 1 \rightarrow 4fucose disaccharide unit. *Biol Pharm Bull*. 34:1635–1639.

Nio-Kobayashi J. 2017. Tissue- and cell-specific localization of galectins, beta-galactose-binding animal lectins, and their potential functions in health and disease. *Anat Sci Int*. 92:25–36.

Nishiyama K, Yamada A, Takahashi M, Takeuchi T, Kasai K, Kobayashi S, Natsugari H, Takahashi H. 2010. Synthesis of fluorescence-labeled Gal β 1-3Fuc and Gal β 1-4Fuc as probes for the endogenous glyco-epitope recognized by galectins in *Caenorhabditis elegans*. *Chem Pharm Bull (Tokyo)*. 58:495–500.

Paschinger K, Razzazi-Fazeli E, Furukawa K, Wilson IB. 2011. Presence of galactosylated core fucose on *N*-glycans in the planaria *Dugesia japonica*. *J Mass Spectrom*. 46:561–567.

Paschinger K, Wilson IB. 2015. Two types of galactosylated fucose motifs are present on *N*-glycans of *Haemonchus contortus*. *Glycobiology*. 25:585–590.

Glycobiology. 2019 Jun 1;29(6):504-512. doi: 10.1093/glycob/cwz022.
<https://academic.oup.com/glycob/article/29/6/504/5381599>

Prasanphanich NS, Mickum ML, Heimbürg-Molinaro J, Cummings RD. 2013.

Glycoconjugates in host-helminth interactions. *Front Immunol.* 4:240.

Preston SJ, Beddoe T, Walkden-Brown S, Meeusen E, Piedrafita D. 2015. Galectin-11: A novel host mediator targeting specific stages of the gastrointestinal nematode parasite, *Haemonchus contortus*. *Int J Parasitol.* 45:791–796.

Rodrigues JA, Acosta-Serrano A, Aebi M, Ferguson MA, Routier FH, Schiller I, Soares S, Spencer D, Titz A, Wilson IB, *et al.* 2015. Parasite glycobiology: a bittersweet symphony. *PLoS Pathog.* 11:e1005169.

Sakakura M, Tamura M, Fujii N, Takeuchi T, Hatanaka T, Kishimoto S, Arata Y, Takahashi H. 2018. Structural mechanisms for the *S*-nitrosylation-derived protection of mouse galectin-2 from oxidation-induced inactivation revealed by NMR. *FEBS J.* 285:1129–1145.

Sato S, St-Pierre C, Bhaumik P, Nieminen J. 2009. Galectins in innate immunity: dual functions of host soluble beta-galactoside-binding lectins as damage-associated molecular patterns (DAMPs) and as receptors for pathogen-associated molecular patterns (PAMPs). *Immunol Rev.* 230:172–187.

Schiller B, Hykollari A, Yan S, Paschinger K, Wilson IB. 2012. Complicated *N*-linked glycans in simple organisms. *Biol Chem.* 393:661–673.

Shi W, Xue C, Su XZ, Lu F. 2018. The roles of galectins in parasitic infections. *Acta Trop.* 177:97–104.

Glycobiology. 2019 Jun 1;29(6):504-512. doi: 10.1093/glycob/cwz022.
<https://academic.oup.com/glycob/article/29/6/504/5381599>

Si Y, Feng S, Gao J, Wang Y, Zhang Z, Meng Y, Zhou Y, Tai G, Su J. 2016. Human galectin-2 interacts with carbohydrates and peptides non-classically: new insight from X-ray

crystallography and hemagglutination. *Acta Biochim Biophys Sin (Shanghai)*. 48:939–947.

Smit CH, van Diepen A, Nguyen DL, Wuhrer M, Hoffmann KF, Deelder AM, Hokke CH.

2015. Glycomic analysis of life stages of the human parasite *Schistosoma mansoni* reveals developmental expression profiles of functional and antigenic glycan motifs. *Mol Cell Proteomics*. 14:1750–1769.

Proteomics. 14:1750–1769.

Subramanian SP, Babu P, Palakodeti D, Subramanian R. 2018. Identification of multiple

isomeric core chitobiose-modified high-mannose and paucimannose *N*-glycans in the

planarian *Schmidtea mediterranea*. *J Biol Chem*. 293:6707–6720.

Takahashi N, Masuda K, Hiraki K, Yoshihara K, Huang HH, Khoo KH, Kato K. 2003. *N*-

Glycan structures of squid rhodopsin. *Eur J Biochem*. 270:2627–2632.

Takeuchi T, Arata Y, Kasai KI. 2016. Galactoseβ1-4fucose: A unique disaccharide unit

found in *N*-glycans of invertebrates including nematodes. *Proteomics*. 16:3137–3147.

Takeuchi T, Hayama K, Hirabayashi J, Kasai K. 2008. *Caenorhabditis elegans* *N*-glycans

containing a Gal-Fuc disaccharide unit linked to the innermost GlcNAc residue are

recognized by *C. elegans* galectin LEC-6. *Glycobiology*. 18:882–890.

Takeuchi T, Nemoto-Sasaki Y, Arata Y, Kasai K. 2011. Galectin LEC-6 interacts with

glycoprotein F57F4.4 to cooperatively regulate the growth of *Caenorhabditis elegans*. *Biol*

Glycobiology. 2019 Jun 1;29(6):504-512. doi: 10.1093/glycob/cwz022.
<https://academic.oup.com/glycob/article/29/6/504/5381599>

Pharm Bull. 34:1139–1142.

Takeuchi T, Nishiyama K, Saito S, Tamura M, Fuwa TJ, Nishihara S, Takahashi H, Natsugari H, Arata Y, Kasai K. 2015. Preparation of a polyclonal antibody that recognizes a unique galactosebeta1-4fucose disaccharide epitope. *Carbohydr Res.* 412:50–55.

Takeuchi T, Nishiyama K, Sugiura K, Takahashi M, Yamada A, Kobayashi S, Takahashi H, Natsugari H, Kasai K. 2009. *Caenorhabditis elegans* galectins LEC-6 and LEC-1 recognize a chemically synthesized Galbeta1-4Fuc disaccharide unit which is present in *Protostomia* glycoconjugates. *Glycobiology.* 19:1503–1510.

Takeuchi T, Nishiyama K, Yamada A, Tamura M, Takahashi H, Natsugari H, Aikawa J, Kojima-Aikawa K, Arata Y, Kasai K. 2011. *Caenorhabditis elegans* proteins captured by immobilized Galbeta1-4Fuc disaccharide units: assignment of 3 annexins. *Carbohydr Res.* 346:1837–1841.

Takeuchi T, Tamura M, Nishiyama K, Iwaki J, Hirabayashi J, Takahashi H, Natsugari H, Arata Y, Kasai K. 2013. Mammalian galectins bind galactosebeta1-4fucose disaccharide, a unique structural component of protostomial *N*-type glycoproteins. *Biochem Biophys Res Commun.* 436:509–513.

Tamura M, Sasai A, Ozawa R, Saito M, Yamamoto K, Takeuchi T, Ohtake K, Tateno H, Hirabayashi J, Kobayashi J, *et al.* 2016. Identification of the cysteine residue responsible for oxidative inactivation of mouse galectin-2. *J Biochem.* 160:233–241.

Glycobiology. 2019 Jun 1;29(6):504-512. doi: 10.1093/glycob/cwz022.
<https://academic.oup.com/glycob/article/29/6/504/5381599>

Tamura M, Sato D, Nakajima M, Saito M, Sasaki T, Tanaka T, Hatanaka T, Takeuchi T, Arata

Y. 2017. Identification of galectin-2-mucin interaction and possible formation of a high molecular weight lattice. *Biol Pharm Bull.* 40:1789–1795.

Tateno H, Minoshima F, Saito S. 2017. Engineering of a potent recombinant lectin-toxin fusion protein to eliminate human pluripotent stem cells. *Molecules.* 22:e1151.

Thiemann S, Baum LG. 2016. Galectins and immune responses-just how do they do those things they do? *Annu Rev Immunol.* 34:243–264.

Titz A, Butschi A, Henrissat B, Fan YY, Hennet T, Razzazi-Fazeli E, Hengartner MO, Wilson

IB, Kunzler M, Aebi M. 2009. Molecular basis for galactosylation of core fucose residues in invertebrates: identification of *Caenorhabditis elegans* N-glycan core alpha1,6-fucoside beta1,4-galactosyltransferase GALT-1 as a member of a novel glycosyltransferase family. *J Biol Chem.* 284:36223–36233.

van den Berg TK, Honing H, Franke N, van Remoortere A, Schiphorst WE, Liu FT, Deelder AM, Cummings RD, Hokke CH, van Die I. 2004. LacdiNAc-glycans constitute a parasite pattern for galectin-3-mediated immune recognition. *J Immunol.* 173:1902–1907.

Varki A, Cummings RD, Aebi M, Packer NH, Seeberger PH, Esko JD, Stanley P, Hart G, Darvill A, Kinoshita T, *et al.* 2015. Symbol nomenclature for graphical representations of glycans. *Glycobiology.* 25:1323–1324.

Vasta GR, Feng C, Gonzalez-Montalban N, Mancini J, Yang L, Abernathy K, Frost G, Palm

Glycobiology. 2019 Jun 1;29(6):504-512. doi: 10.1093/glycob/cwz022.
<https://academic.oup.com/glycob/article/29/6/504/5381599>

C. 2017. Functions of galectins as 'self/non-self'-recognition and effector factors. *Pathog Dis.* 75.

Walser PJ, Haebel PW, Kunzler M, Sargent D, Kues U, Aebi M, Ban N. 2004. Structure and functional analysis of the fungal galectin CGL2. *Structure.* 12:689–702.

Wuhrer M, Robijn ML, Koeleman CA, Balog CI, Geyer R, Deelder AM, Hokke CH. 2004. A novel Gal(beta1-4)Gal(beta1-4)Fuc(alpha1-6)-core modification attached to the proximal *N*-acetylglucosamine of keyhole limpet haemocyanin (KLH) *N*-glycans. *Biochem J.* 378:625–632.

Yan S, Bleuler-Martinez S, Plaza DF, Kunzler M, Aebi M, Joachim A, Razzazi-Fazeli E, Jantsch V, Geyer R, Wilson IB, *et al.* 2012. Galactosylated fucose epitopes in nematodes: increased expression in a *Caenorhabditis* mutant associated with altered lectin sensitivity and occurrence in parasitic species. *J Biol Chem.* 287:28276–28290.

Yan S, Brecker L, Jin C, Titz A, Dragosits M, Karlsson NG, Jantsch V, Wilson IB, Paschinger K. 2015. Bisecting galactose as a feature of *N*-glycans of wild-type and mutant *Caenorhabditis elegans*. *Mol Cell Proteomics.* 14:2111–2125.

Yan S, Wilson IB, Paschinger K. 2015. Comparison of RP-HPLC modes to analyse the *N*-glycome of the free-living nematode *Pristionchus pacificus*. *Electrophoresis.* 36:1314–1329.

Yang RY, Rabinovich GA, Liu FT. 2008. Galectins: structure, function and therapeutic potential. *Expert Rev Mol Med.* 10:e17.

Glycobiology. 2019 Jun 1;29(6):504-512. doi: 10.1093/glycob/cwz022.
<https://academic.oup.com/glycob/article/29/6/504/5381599>

Zhang Y, Iwasa T, Tsuda M, Kobata A, Takasaki S. 1997. A novel monoantennary complex-type sugar chain found in octopus rhodopsin: occurrence of the Gal beta1-->4Fuc group linked to the proximal N-acetylglucosamine residue of the trimannosyl core. *Glycobiology* 7:1153–1158.

FIGURE LEGENDS

Figure 1. Galectin-2 suppresses *C. elegans* development

Effects of various galectins on the development of *Caenorhabditis elegans*. L1 larval stage of *C. elegans* was seeded and grown in liquid medium with various galectins for 63-69 h at 20 °C. The percentages of animals developing to the L4 stage were scored. Data are expressed as means \pm SD. N.D. = not detected.

Figure 2. Gal-2 binds to *C. elegans* intestinal glycoconjugates *in vivo* in a lactose-dependent manner

Mixed-stage *C. elegans* were stained with Alexa488-labeled Gal-2 and washed with 0.1 M maltose (osmotic control) or lactose. Bright-field images and fluorescent images of larval worms (possibly L2 or L3 stage) were taken. Their merged images are also presented.

Figure 3. Gal-2 binds to *C. elegans* glycoconjugates with GalFuc epitope *in vitro*

An extract of mixed-stage *C. elegans* was applied to an immobilized Gal-2 column. Following extensive washing, the bound materials were eluted with 0.1 M lactose. Successive fractions were collected and subjected to SDS-PAGE followed by Coomassie brilliant blue (CBB) staining (A) or immunoblotting analysis with anti-GalFuc antibody (B). The indicated

bands of Gal-2 binding glycoconjugates were subjected to protein identification by LC-MS/MS (C).

Figure 4. Gal-2 recognizes GalFuc epitope in natural *C. elegans* N-glycans

(A) Structures of the PA-sugars used in frontal affinity chromatography. The symbols used comply with the standard nomenclature for graphical representations of glycans (Varki et al. 2015). ‘Me’ = methyl group. The hexose residue in the trimannosyl core structure of *C. elegans* glycans may be bisecting galactose (Yan et al. 2015).

(B) Bar graph of K_a for the interaction between mouse Gal-2 and PA-sugars. K_a were calculated as described in the Materials and Methods section.

Figure 5. Gal-2 binds to *Ascaris* glycoconjugates with GalFuc epitope which is found in other parasitic nematodes

(A) A commercially available *Ascaris* extract was applied to an immobilized Gal-2 column. Following extensive washing, the bound materials were eluted with 0.1 M lactose. Successive fractions were collected and subjected to western blotting with anti-GalFuc antibody.

(B) Extracts of human HeLa cells, the parasitic nematodes *N. brasiliensis* (Nb) (L4 and L5 stages) and *B. pahangi* (L3 stage), and the parasitic trematode *S. mansoni* (Sm) (egg and adult) were prepared and subjected to western blotting with anti-GalFuc antibody.

Figure 1. Takeuchi et al.

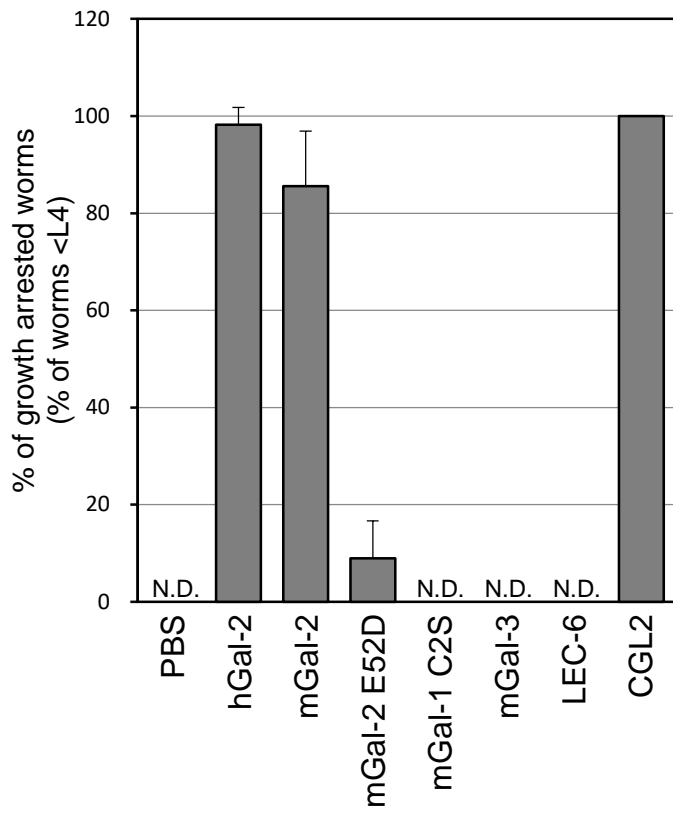

Figure 2. Takeuchi et al.

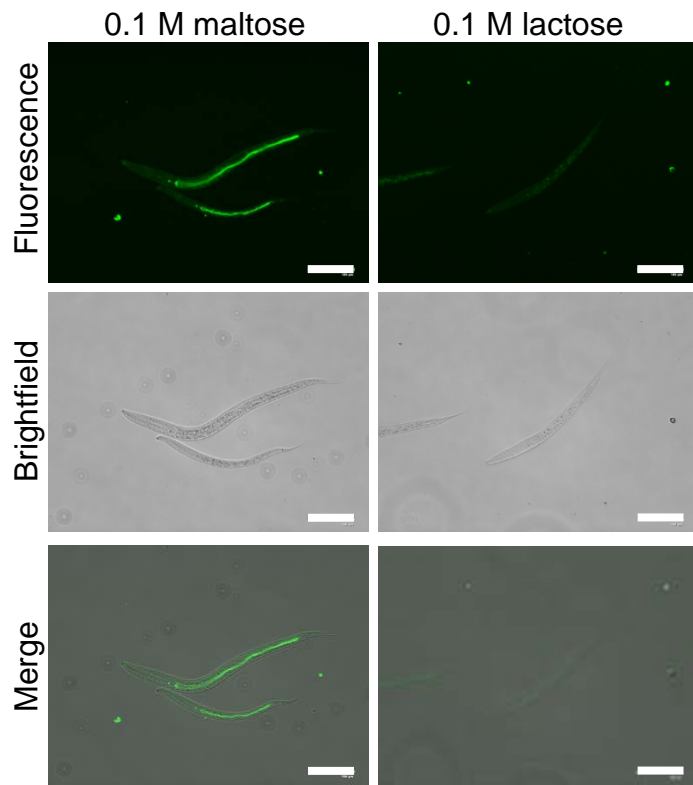

Figure 3. Takeuchi et al.

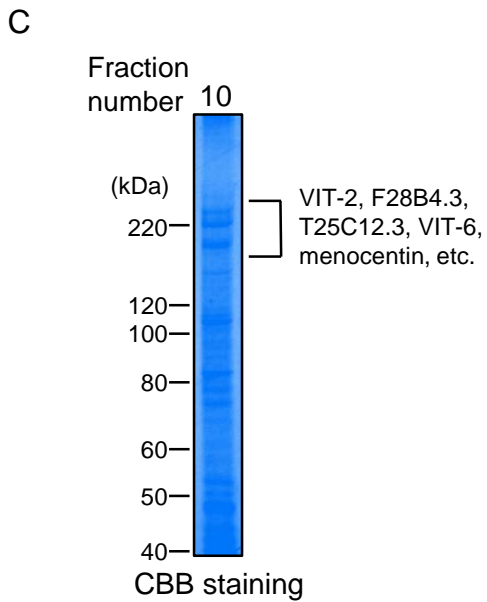
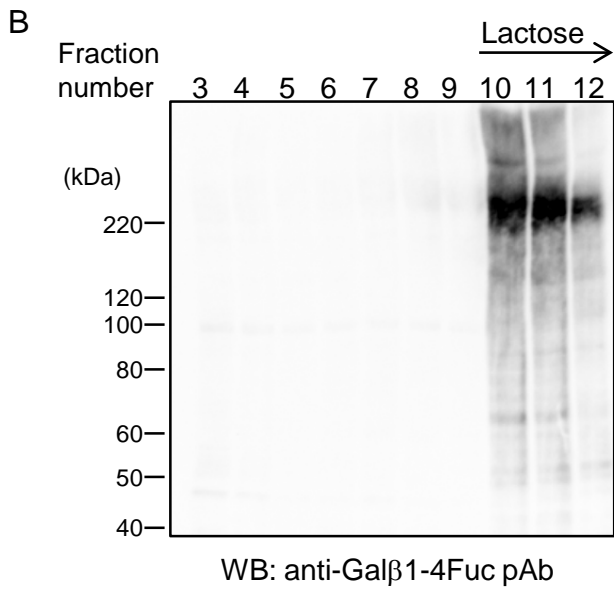
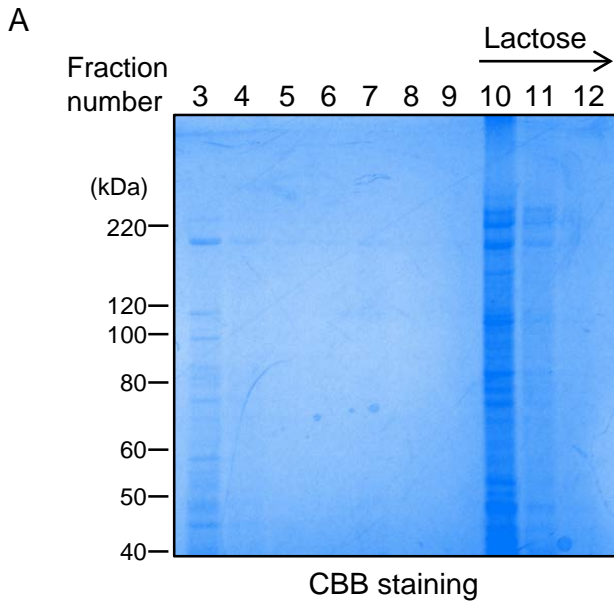
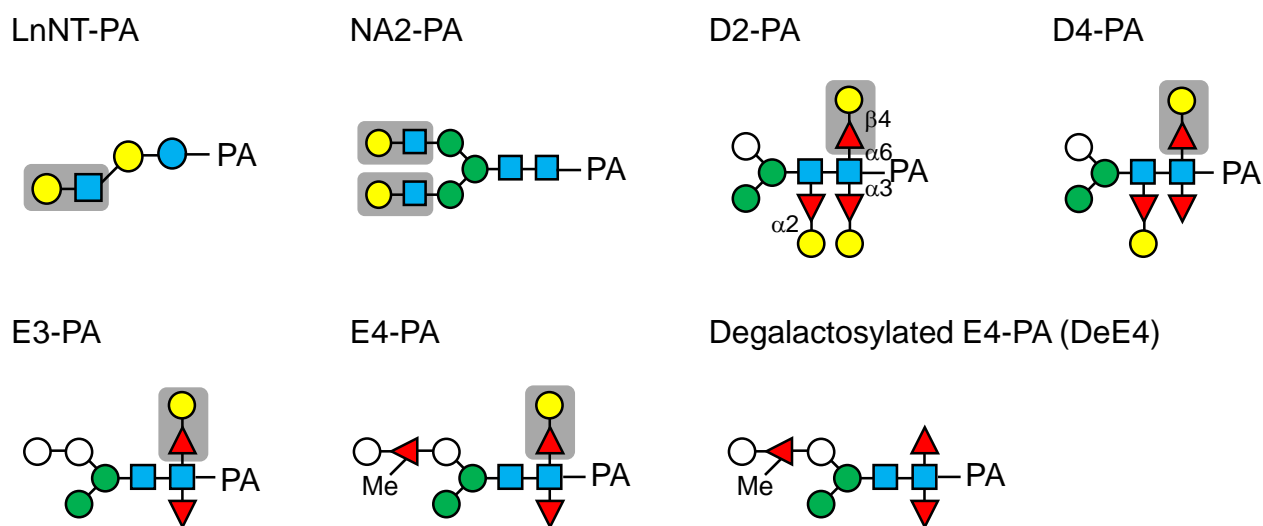

Figure 4. Takeuchi et al.

A



B

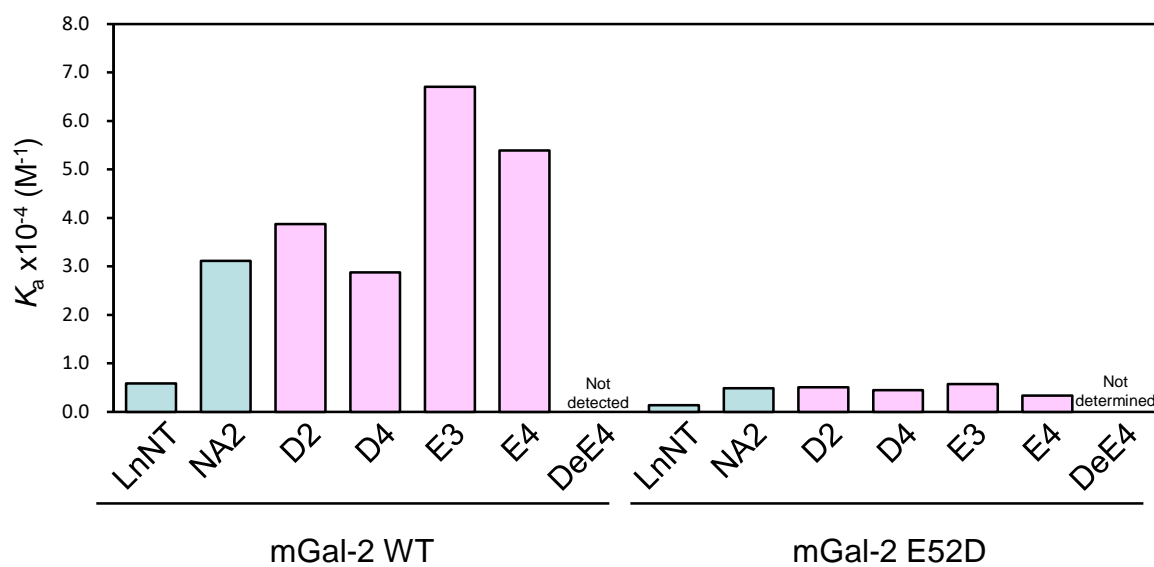

Figure 5. Takeuchi et al.

